

K8



SUPAPANEL®



Performance Guide



the next generation of aerated panels





K8



SUPAPANEL®

K8 Australia has developed a panel based system for providing non-load bearing fire and acoustic rated walls. Using various steel thicknesses and concrete core densities to optimise cost and weight throughout the building project.

Australian Made

K8 SUPAPANEL® is manufactured in Springvale, Victoria by K8 Australia PTY LTD. Manufactured to the highest quality standards, we guarantee to use only quality materials in our manufacturing processes. K8 SUPAPANEL® is wholly Australian owned and manufactured from locally sourced materials.

K8 Australia is mindful of the environment and where ever possible always uses recycled components during the manufacturing process including our water system which enables us to have zero waste water leave our plant.

BENEFITS

- Lightweight, narrow footprint, secure, fire and acoustic rated.
- K8 SUPAPANEL® can be manufactured to various steel thicknesses and concrete core densities optimising costs and weight throughout the building project.
- Is a simple modular system which is easy to handle and assemble with rapid installation.
- Demountable and re-usable.
- Has 40% more coverage per panel than other equivalent systems in the market.
- Provides a high level of security in comparison to other systems.
- Provides an instant water resistant weather barrier for exposed applications.
- Tested in accordance with AS 1530.4:2014 for Fire resistance performance.
- Compliant with the latest fire standards and building codes of Australia.
- Manufactured in Australia.
- Reusable panels.

APPLICATIONS

- Commercial and office towers.
- High rise / high density residential.
- Shopping centres, supermarkets.
- Hospitals.
- Cinemas.
- Metropolitan and rural.
- Industrial.
- Factories.

REPLACEMENT FOR

- Office shaft risers and complete vertical duct risers.
- Lightweight concrete block walls and non load bearing pre- cast walls.
- High quality intertenancy wall systems.
- Plenum for mechanical systems.
- Fire rated wall systems.
- Light weight plasterboard walls.

K8 SUPAPANEL® is manufactured from roll formed galvanised steel shells or coloured steel shells filled with a lightweight aerated concrete core.

K8 SUPAPANEL® provides a secure, non-load bearing fire and acoustic rated wall system with a narrow footprint. Each panel interlocks with a male/female joint system for simplicity and to provide rapid installation.

Table of Contents

Performance Guide

About Us	2
Design Considerations	5
Panel Weight	5
72mm Span Capacities	6
62mm Span Capacities	6
Technical Data - Fire	7
Technical Data - Acoustic	9
Technical Data - Wind	10

Shaft Systems

Straight Shaft Construction	14
Shaft Construction to Structural Wall	18

Stair Systems

Typical Double + Single Stair Options	20
Fire Shielding	22
Junction Details	23
Recess Posts	25
Mid Section Posts	28
Handrail Fitting Variation	29

Other Documents

Manufacturer's Statement	30
Publication Control	31
Contact Us	32

K8



SUPAPANEL®



Design Considerations

We are committed to ensuring K8 SUPAPANEL® meets and exceeds all current mandatory Australian standards for building projects Australia wide. To assist in performance solutions, K8 SUPAPANEL® supplement fire testing as well as organising a fully qualified engineer to cater for all applications on site for fire rated wall compliance.

Fire	K8 SUPAPANEL® systems have been tested to AS1530.4 to determine their fire resistance performance and tested to AS1530.1 to confirm their non-combustible product properties. We can provide Engineering performance based solutions for different scenarios of use outside testing fields
Acoustics	K8 SUPAPANEL® systems have been tested by Marshall Day Acoustics in accordance with AS1191 for acoustic ratings of the panels and wall systems.
Wind load deflection	All wind loading deflection has been undertaken by NATA registered laboratories in accordance with AS4040.2-1992 (non-cyclone regions).
Seismic	Please contact us for more information.
Cyclonic	Please contact us for more information.
Structural	Non load bearing panels are self supporting. Structural building design is required for the system.
Air infiltration	K8 SUPAPANEL® can be used as a fire rated pressurised plenum or shaft that is required to be air tight. NATA approved pressure testing available with relevant leakage rate versus pressure.

Panel Weight

K8 SUPAPANEL® Weight of Panels							
Panel Density concrete core		425kg/m ³	450kg/m ³	500kg/m ³	650kg/m ³	800kg/m ³	1000kg/m ³
Weight per 1m (kg)	62mm	12.05	12.96	14.15	17.40	20.56	25.00
	72mm	13.00	14.46	15.72	19.5	23.28	28.32
Weight per m2 (kg)	62mm	35.71	36.95	40.32	49.60	58.59	71.25
	72mm	38.00	41.21	44.80	55.57	66.34	80.71

72mm K8 Supapanel **Span Capacities**

Profile	72mm K8 SUPAPANEL®			
Fire rating (FRL)	-/120/120			
Direction of fire	Both directions			
Panel orientation	Vertical	Horizontal	Shaft	Stairs
Max span between structure	6.5m	6.5m	6.5m cross walls connected to a primary wall total length 6.5m	6.5m
Max wall length (single span)	Unlimited	Unlimited	Unlimited	Unlimited

62mm K8 Supapanel **Span Capacities**

Profile	62mm K8 SUPAPANEL®			
Fire rating (FRL)	-/180/90 with single sided caulked joints -/180/60 no caulked joints			
Direction of fire	Both directions			
Panel orientation	Vertical	Horizontal	Shaft	Stairs
Max span between structure	4.0m	4.0m	4.0m with 4.0m cross walls attached	4.2m Single span with light weight structural steel of 8.0m. Double spans with light weight structural steel 8.2m
Max wall length (single span)	Unlimited	Unlimited	Unlimited	Unlimited

Technical Data **Fire**

SYSTEM	DETAILS	FRL	WALL WIDTH
1A	62mm bare K8 SUPAPANEL® with 425kg core, 0.30 BMT steel shell. Screw fixings only on one side of the wall, no fixing in the head track, free floating.	-/180/60	62mm
Shaft 1A	62mm K8 SUPAPANEL® with 425kg core, 0.35BMT steel shell with 1 x 13mm Fireshield on 16mm furring channel. Screw fixings only on one side of the wall, no fixing in the head track, free floating.	-/180/90	91mm
Shaft 2A	62mm K8 SUPAPANEL® with 425kg core, 0.35BMT steel shell with 1 x 16mm Fireshield on 16mm furring channel. Screw fixings only on one side of the wall, no fixing in the head track, free floating.	-/180/120	94mm
Shaft 4	Bare 72mm K8 SUPAPANEL® with 425kg core, 0.35BMT steel shell.	-/120/120	72mm

K8 SUPAPANEL® wall testing after a 4 hour fire test carried out by Warrington Fire Testing & Certification



Technical Data Fire



TEST CERTIFICATE

No. C23046

This is to certify that the specimens described below were tested by the FireTS Laboratory - Passive Fire Inspection and Test Services Ltd – Accreditation No 1335 - in accordance with AS 1530.4-2014 – Method for fire tests on building materials, components and structure – Section 3 – Walls. Vertical separating elements, on behalf of:

Wall Technologies Pty Ltd

Kilsyth South, Victoria, 3137, Australia

Separating element description:

Nominal 3m high x 3m wide x 72mm thick prefabricated non-loadbearing wall system made of vertical Supapanel panels with special joints, head and side track details.

Product description:

Steel Shell 0.35mm BMT Supapanel Panel with lightweight aerated concrete core of 425kg/m³ nominal density with custom-made tongue and groove vertical joint. Width of the panel - 410mm (insert fitted coverage - 350mm).

Test results

Structural adequacy	Not Applicable
Integrity	127 minutes
Insulation	127 minutes
Fire resistance level (FRL)	-/120/120

This certificate is provided for general information only and does not comply with the regulatory requirements for evidence of compliance.

A full description of the test specimen, proposed installation and the complete test results are detailed in the Tests Report PF23046.

Issued by

Alexey Kokorin
Technical Manager

Date: 13th of September 2023

Passive Fire Inspection and Test Services Limited
1/113 Pavilion Drive, Mangere, Auckland 2022, New Zealand
www.firelab.co.nz

Technical Data **Acoustic**

72mm Acoustic Ratings - Opinion						
SYSTEM	DETAILS	DnTw	Ctr	Net	FRL	WALL WIDTH
Shaft 4	Bare 72mm K8 SUPAPANEL® with 425kg core 0.35BMT steel shell.	36	-3	33	-/120/120	72mm
Shaft 4A	Bare 72mm K8 SUPAPANEL® with 425kg core 0.35BMT steel shell with 1 layer of 13mm fire rated plasterboard on one side with 16mm batten.	43	-5	38	-/120/120	101mm
Shaft 4B	Bare 72mm K8 SUPAPANEL® with 425kg core 0.35BMT steel shell with 1 layer of 13mm fire rated plasterboard on one side. Bettafix clip and Bradford insulation 25mm x 18kg.	50	-9	41	-/120/120	113mm
Tenancy 4A	Bare 72mm K8 SUPAPANEL® with 425kg core 0.35BMT steel shell with 1 layer of 13mm fire-rated plasterboard on 16mm furring channel with no insulation. 20mm cavity on opposite side. 51mm 0.50 stud wall. 13mm plasterboard and 75mm x 14kg glasswool insulation.	58	-10	48	-/120/120	197mm
Tenancy Shaft 5A	72mm K8 SUPAPANEL® with 425kg core 0.35BMT steel shell. 20mm cavity on other side 51mm, 0.5 Knauf stud 13mm RE PB and 75mm x 14kg Bradford insulation.	57	-9	48	-/120/120	156mm

62mm Acoustic Ratings - Performed by Marshall Day Field Testing						
SYSTEM	DETAILS	DnTw	Ctr	Net	FRL	WALL WIDTH
1A	62mm bare K8 SUPAPANEL® with 425kg core, 0.35BMT steel shell	35	-3	32	-/180/60	62mm
Shaft 1B	62mm K8 SUPAPANEL® with 425kg core, 0.35BMT steel shell with 1x13mm Fireshield on 28mm gap and 25mmx18kg Bradford insulation	49	-9	40	-/180/90	103mm
Tenancy 1B	62mm K8 SUPAPANEL® with 425kg core, 0.35BMT steel shell with 1x13mm RE plasterboard, 28mm gap and no insulation. 20mm cavity on other side, 51mm, 0.5mm Knauf stud, 13mm REPB and 75mmx14kg Bradford insulation.	55	-9	46	-/180/60	187mm
Apartment Shaft 3A	62mm K8 SUPAPANEL® with 425kg core, 0.35BMT steel shell. 20mm cavity on other side, 51mm, 0.5mm Knauf stud, 13mm REPB and 75mmx14kg Bradford insulation.	56	-9	47	-/180/60	146mm

Marshall Day Acoustics Pty Ltd (MDA) was commissioned by K8 Australia Pty Ltd to undertake airborne sound insulation testing of proto-type wall panel systems within their dedicated test facility.

Other tested systems are available on request.

K8 SUPAPANEL® verberation chamber - Acoustic testing



Technical Data **Wind Loads**

DETAILS	WALL HEIGHT	Pa
72mm K8 SUPAPANEL® with 425kg core, 0.30BMT steel shell	6.5m	250
62mm K8 SUPAPANEL® with 425kg core, 0.30BMT steel shell	4.0m	780

K8 SUPAPANEL® wind test being performed



K8 SUPAPANEL® onsite install



Technical Data Wind Loads

72mm wind load span charts as per Robert Bird Engineering

Note: Full report requires verification before of project application

Pressure (Pa)	Maximum Supapanel Height (m)			
	L/150	L/200	L/250	L/300
250	6.5	6.5	6.5	6.2
375	6.5	6.4	6.1	5.7
500	6.4	5.9	5.4	5.1
625	6.0	5.4	5.0	4.7
750	5.6	5.1	4.7	4.4
875	5.4	4.9	4.5	4.2
1000	4.9	4.4	4.1	3.8
1125	4.7	4.2	3.9	3.7
1250	4.5	4.1	3.8	3.6
1375	4.4	3.9	3.7	3.4
1500	4.2	3.8	3.6	3.3
1625	4.1	3.7	3.5	3.3
1750	4.0	3.6	3.4	3.2
1875	3.9	3.6	3.3	3.1
2000	3.7	3.3	3.1	2.9
2125	3.6	3.3	3.0	2.9
2250	3.5	3.2	3.0	2.8
2375	3.5	3.2	2.9	2.8
2500	3.4	3.1	2.9	2.7
2625	3.4	3.0	2.8	2.7
2800	3.3	3.0	2.8	2.6
2925	3.2	2.9	2.7	2.6
3050	3.2	2.9	2.7	2.5

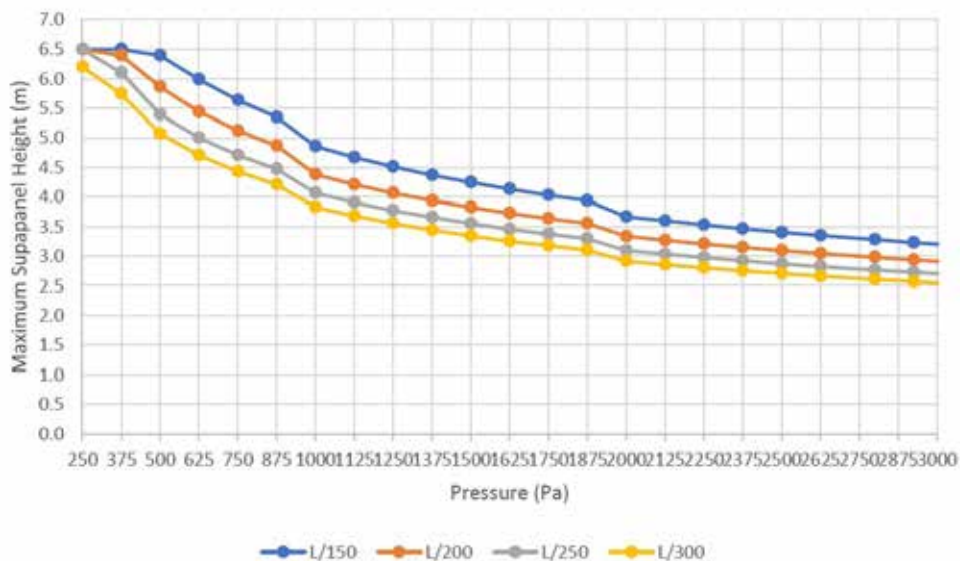

Technical Data **Wind Loads**

62mm wind load span charts as per Robert Bird Engineering

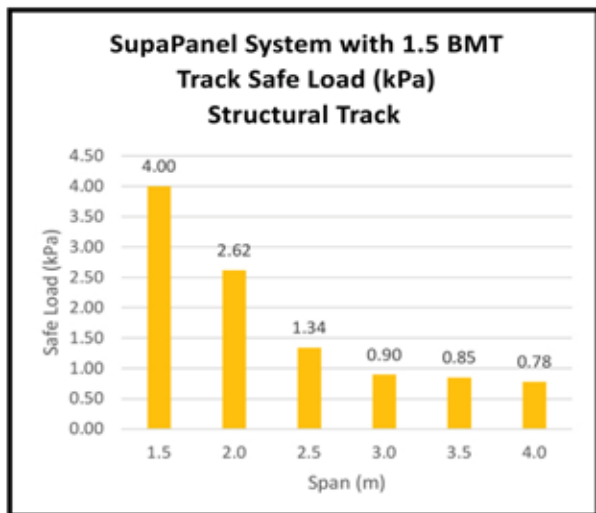
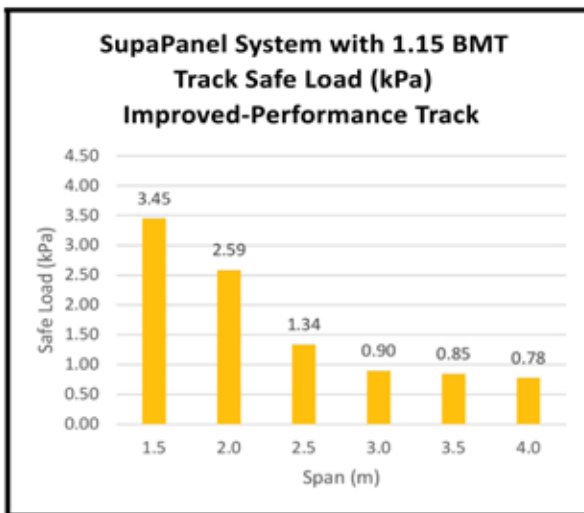
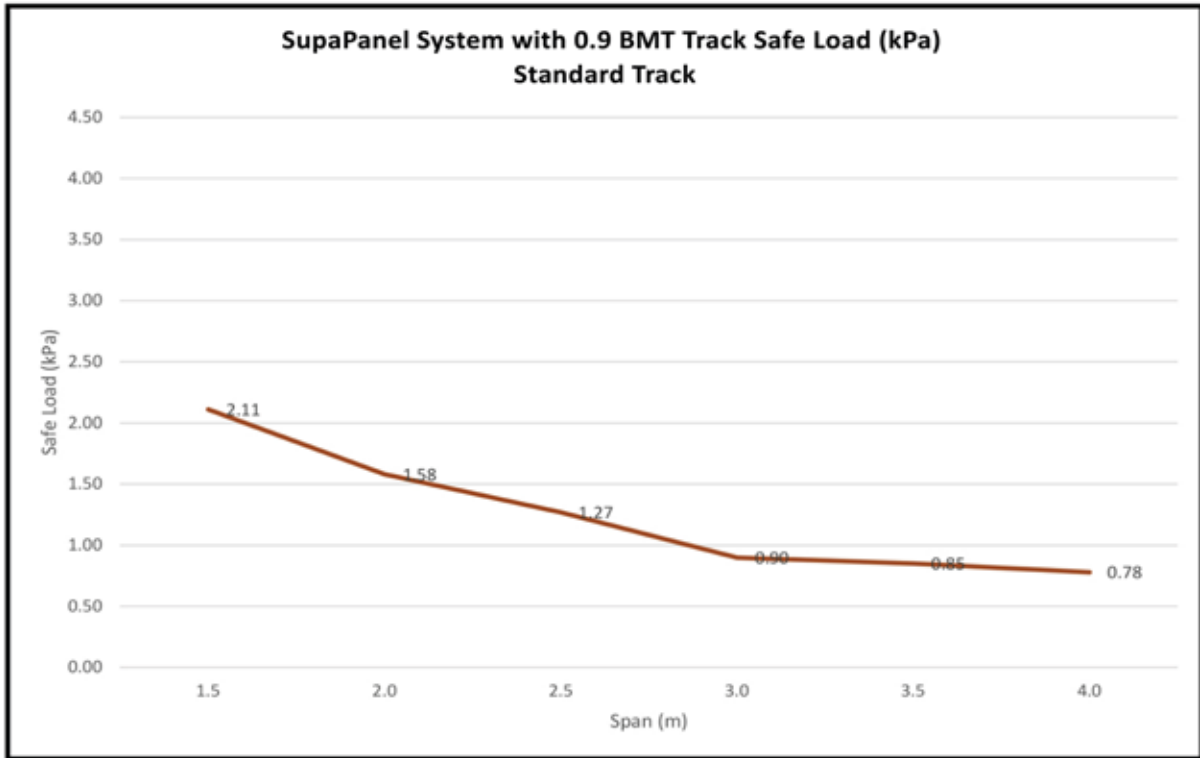

K8



SUPAPANEL®



Shaft Systems



the next generation of aerated panels



2.0 SHAFT CONSTRUCTION

72mm -/120/120

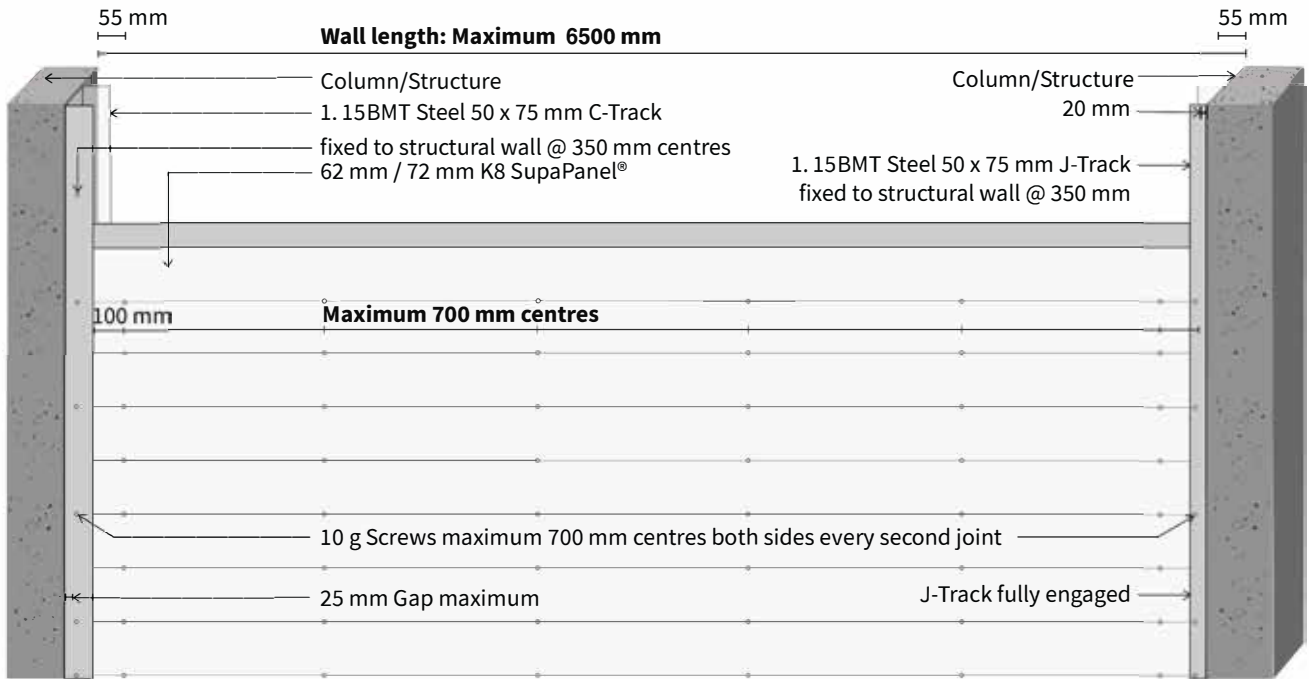

72MM SHAFT JOINT

-/120/120

72MM SHAFT JOINT

-/120/120

HORIZONTAL K8 SUPAPANEL SYSTEM

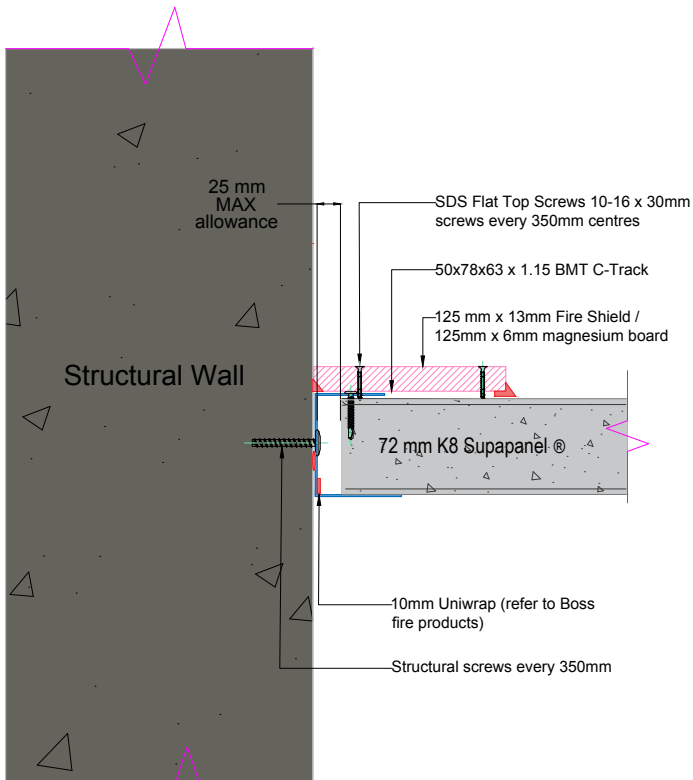

** 25 MM GAP ALLOWANCE IN THE TOP TRACK **

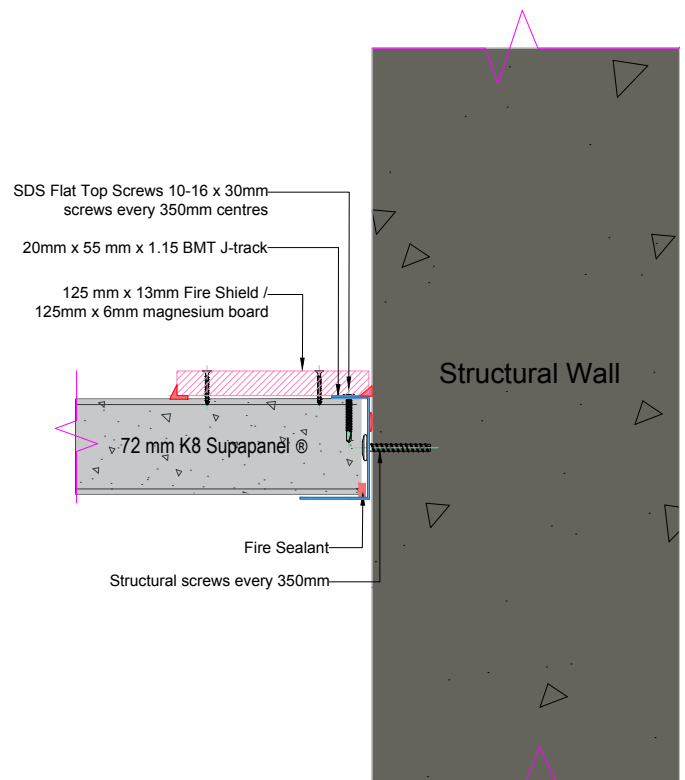

** J TRACK IS FULLY ENGAGED **

2.0 SHAFT CONSTRUCTION

62mm -/180/90
SEALED JOINTS

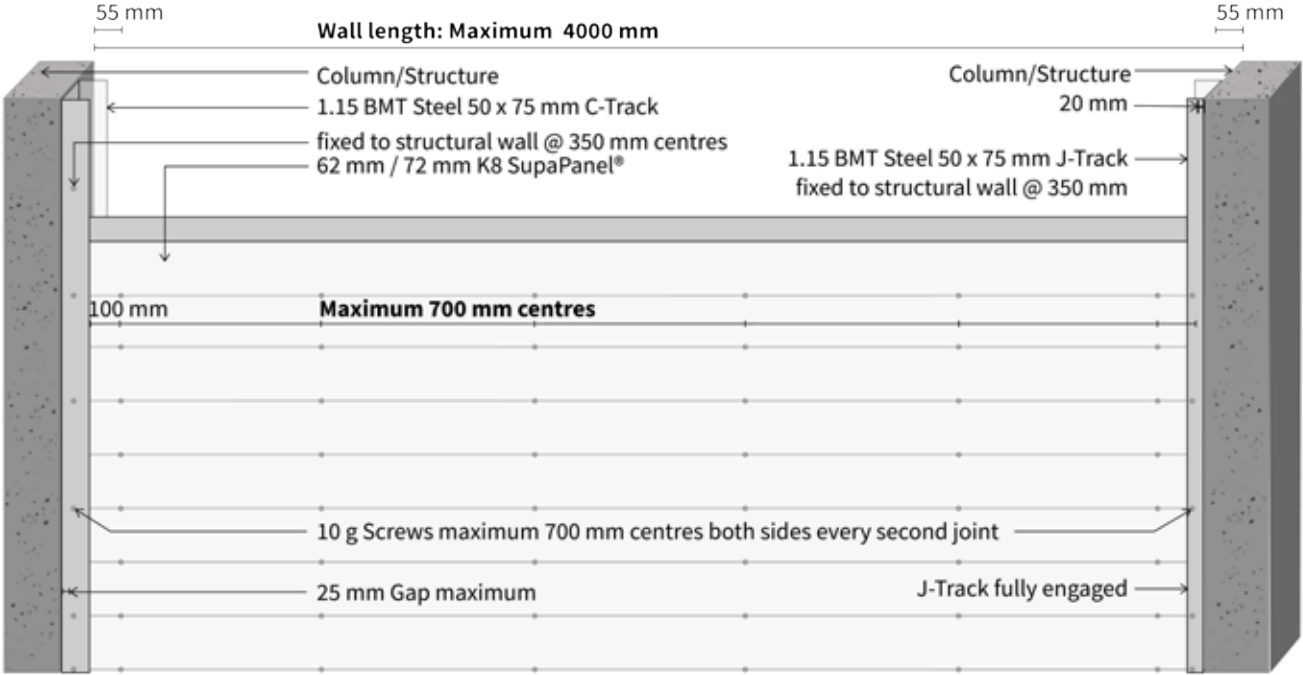

62MM SHAFT JOINT

-/180/90
SEALED JOINTS

62MM SHAFT JOINT

-/180/90
SEALED JOINTS

HORIZONTAL K8 SUPAPANEL SYSTEM

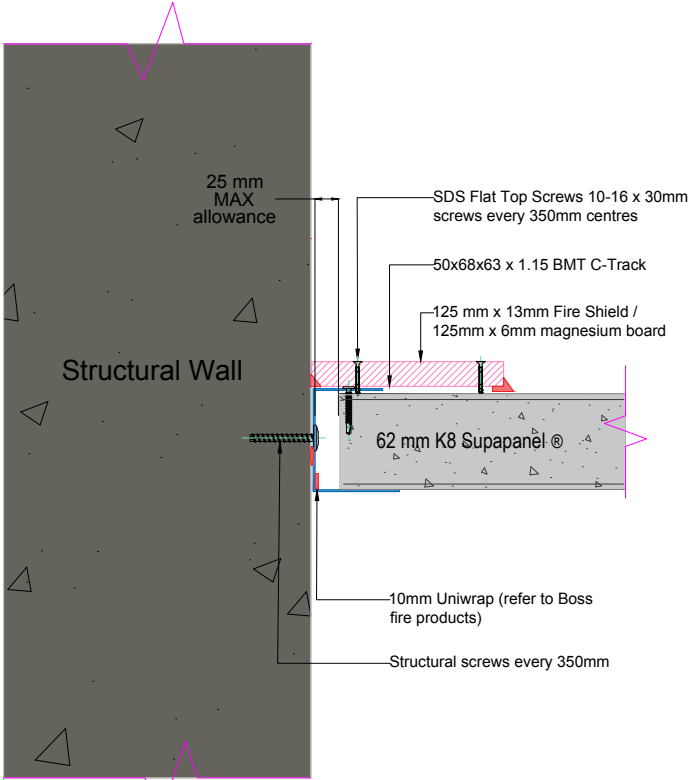

** 25 MM GAP ALLOWANCE IN THE TOP TRACK **

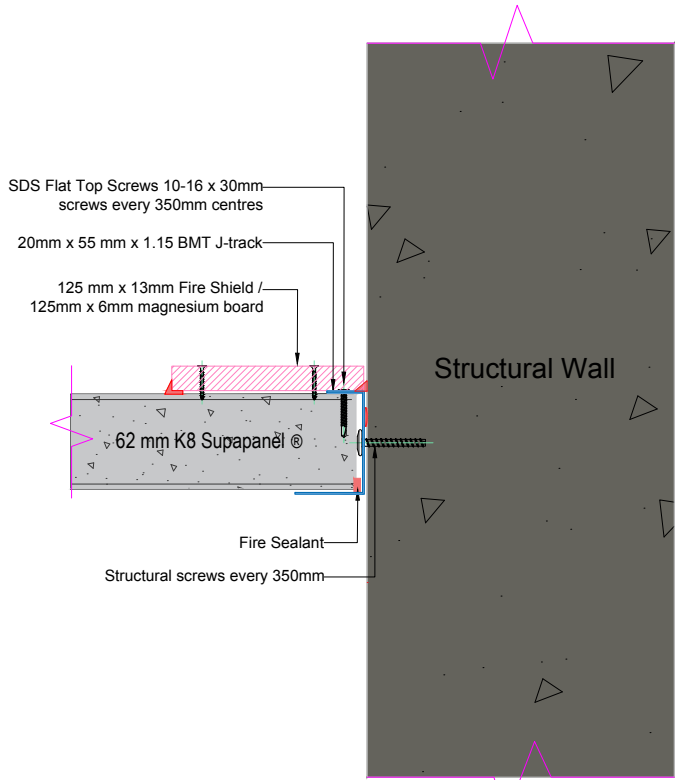

** J TRACK IS FULLY ENGAGED **

2.1 FULL SHAFT CONSTRUCTION WITH SUPAPANEL

72mm -/120/120

VERTICAL TO HORIZONTAL TYPICAL DETAILS

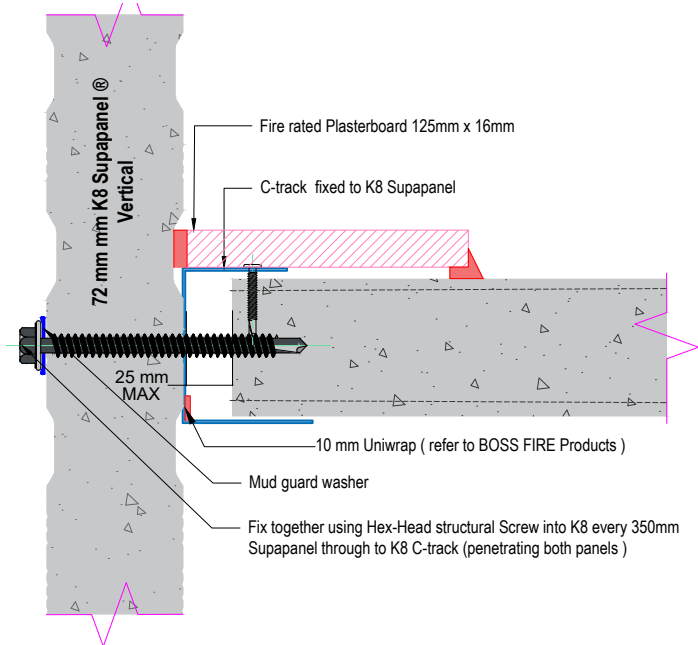

HORIZONTAL TO HORIZONTAL TYPICAL DETAILS

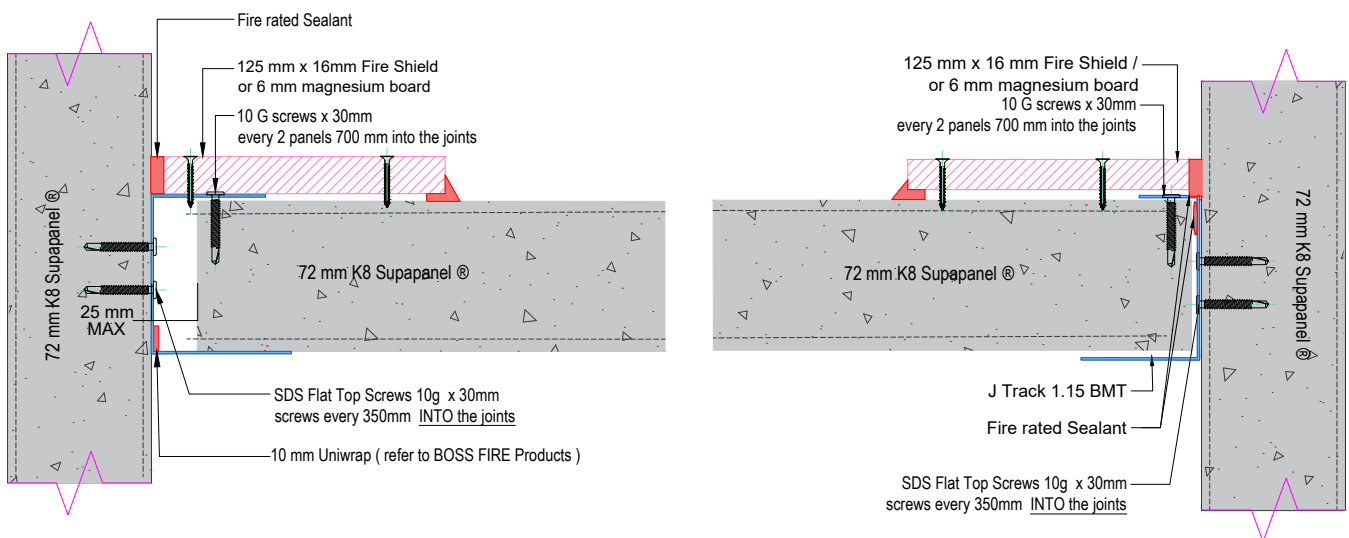

62MM SHAFT JOINT

-/180/90
SEALED JOINTS

62MM SHAFT JOINT

-/180/90
SEALED JOINTS

C-TRACK SYSTEM

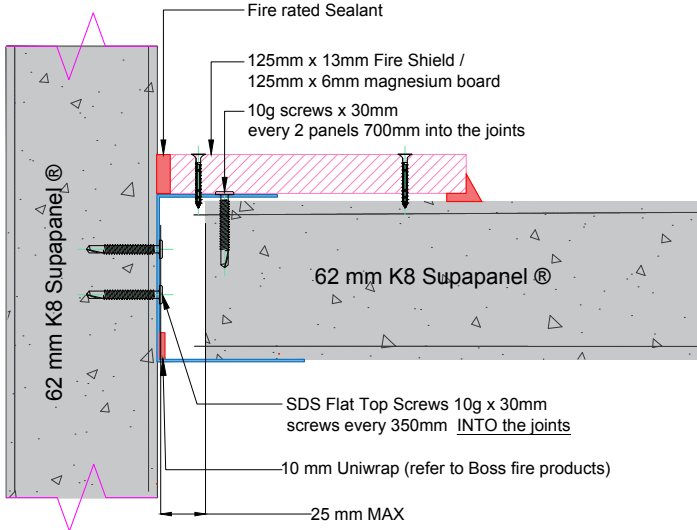

** 25 MM GAP ALLOWANCE IN THE TOP TRACK **

J-TRACK SYSTEM

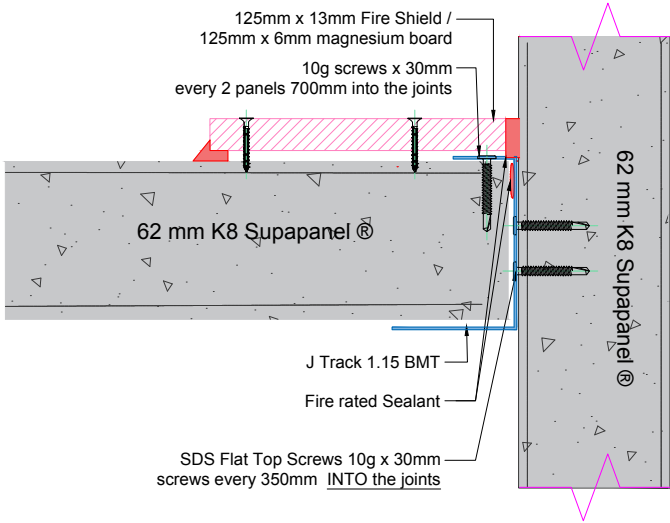

** J TRACK IS FULLY ENGAGED **

2.2 HANGING SHAFT CONSTRUCTION TO STRUCTURAL WALL

OPTIONS

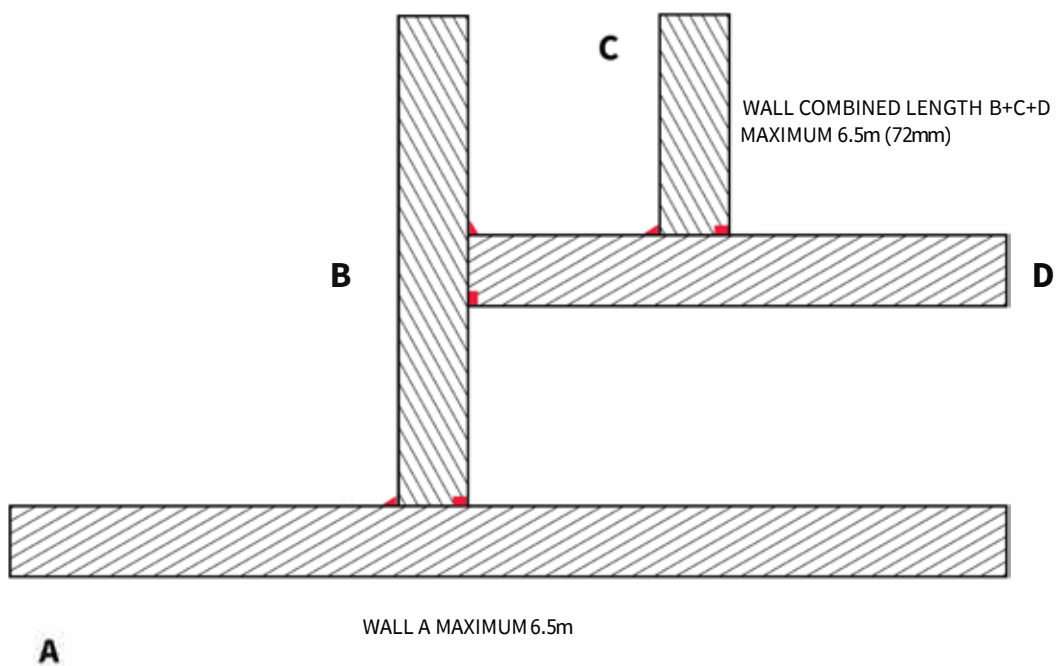
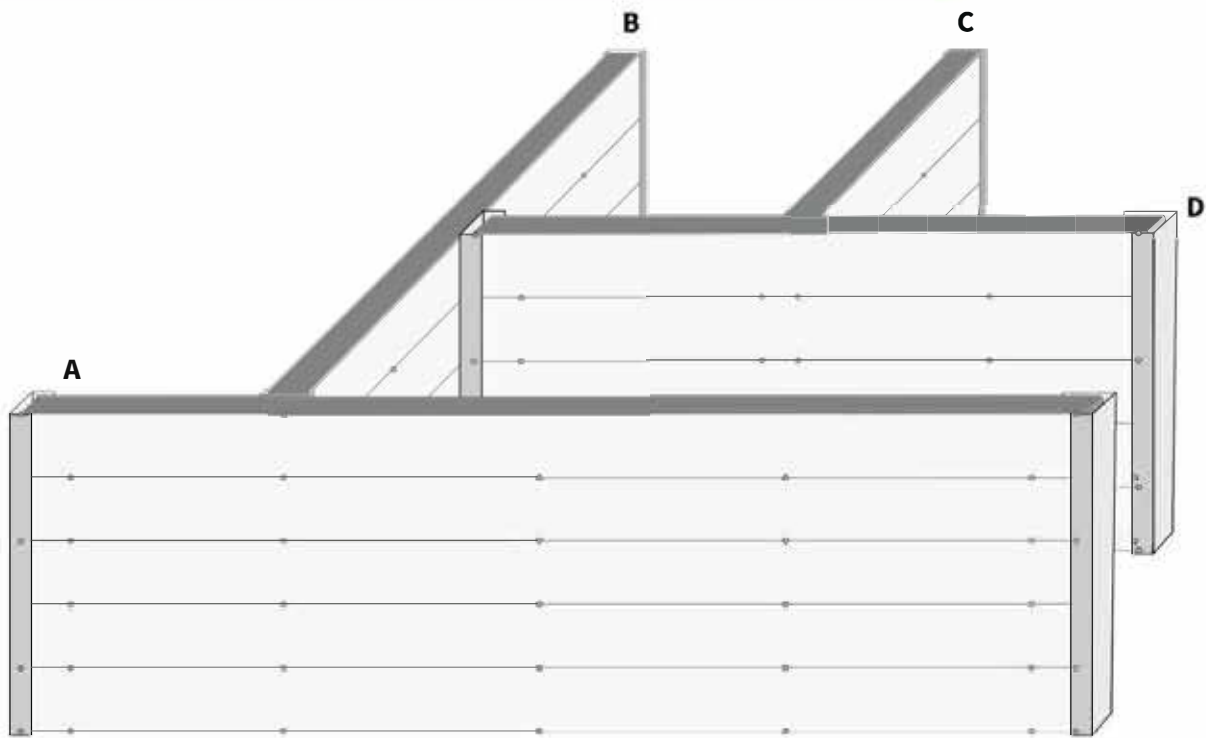

K8



SUPAPANEL®



Stair Systems



the next generation of aerated panels



3.0 TYPICAL DOUBLE STAIR EXAMPLE

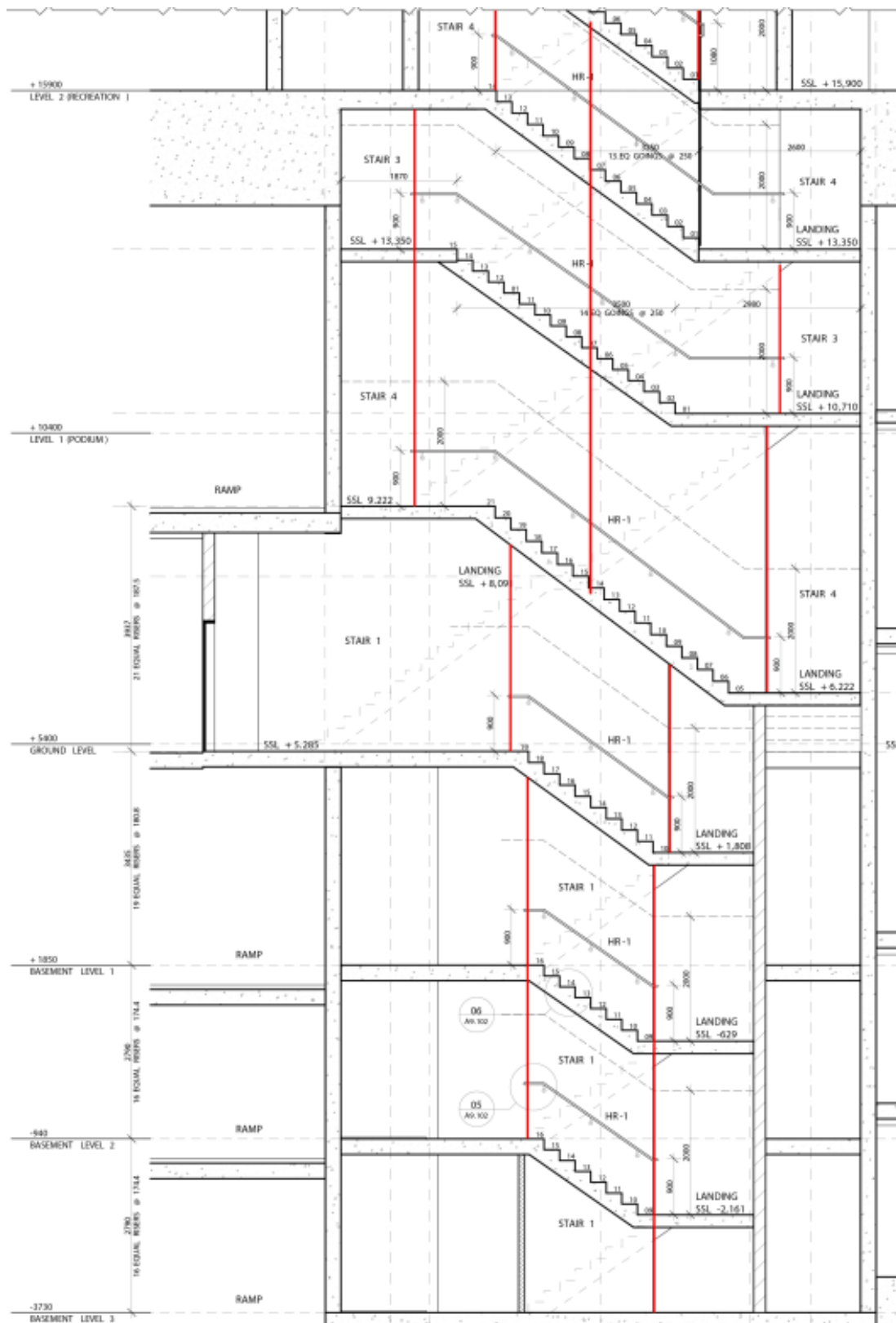

NOTES:

- Maximum vertical column height is 4.8m. If longer spans are required, a job specific engineer will need to be engaged.
 - This design assumes the stair engineering takes into account the weight of columns and stair concrete is minimum 32mp's.
 - Columns have been designed for lateral wind load of 250Pa's. If columns are to be designed larger than this job, a specific engineer will need to be engaged.
 - The gap between stair landings at the column connection points is assumed to be maximum 85mm. If greater than this, a job specific engineer will need to be engaged.
 - If other site conditions vary from those specified on these plans, a job specific engineer will need to be engaged.
- * RED LINE INDICATES THE ADDED POST
- * RHS 35 X 65 X 4mm.

3.1 TYPICAL SINGLE STAIR OPTION

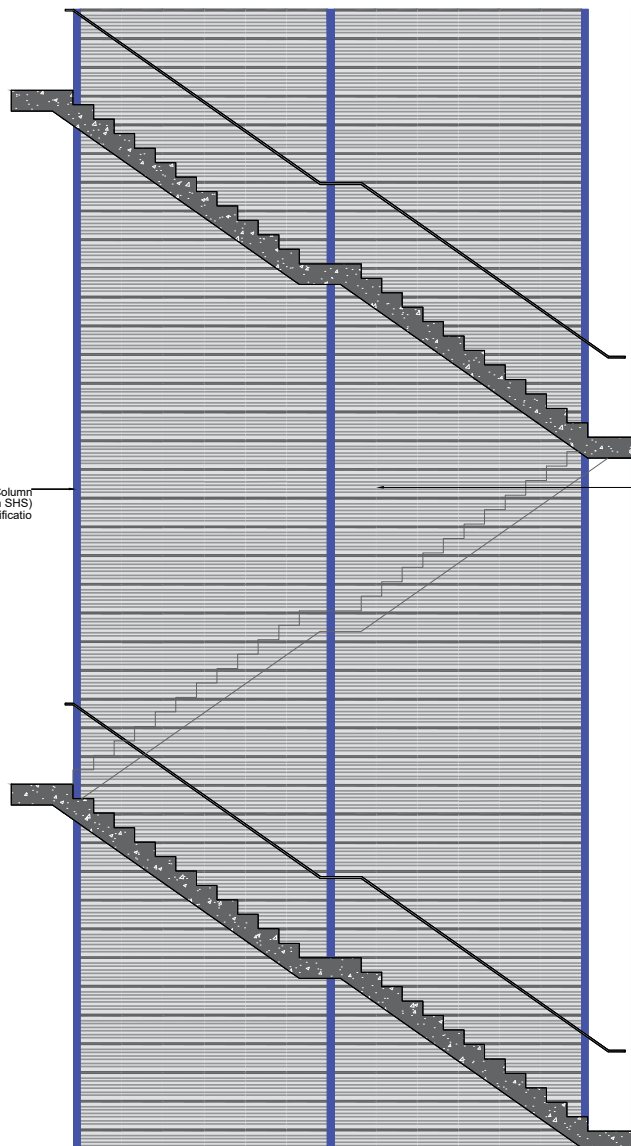

Supporting Column
(Recommended 35 * 65 * 4mm SHS)
Please refer to Engineers for further clarification

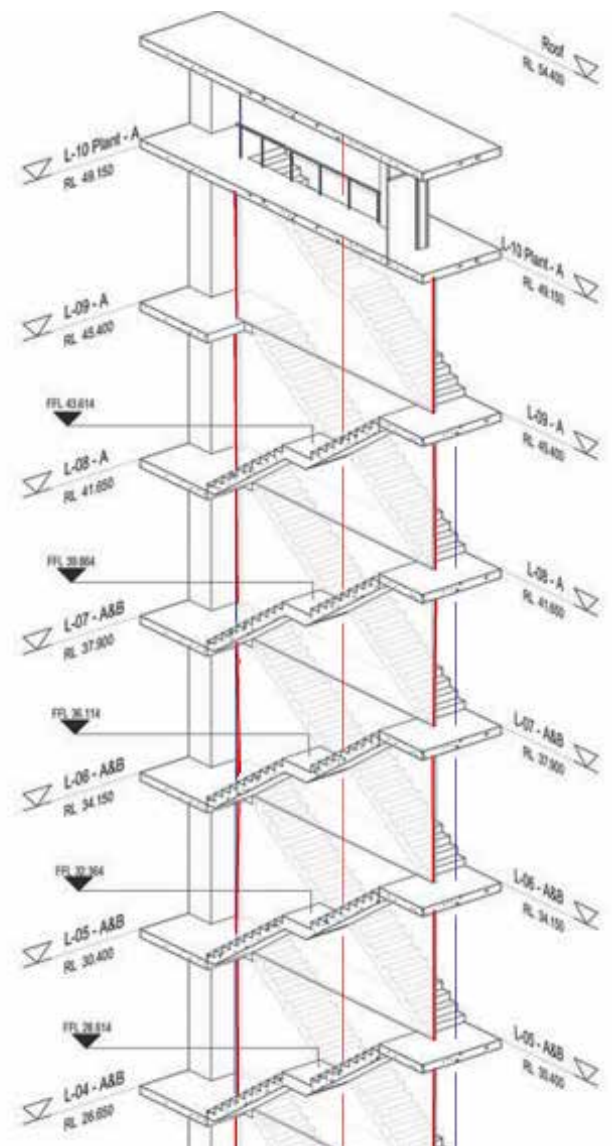

* BLUE LINE INDICATES THE ADDED COLUMN.

- Recommended SHS 65 x 45 x 4mm.
- The gaps between the wall & the stair could easily be sealed and covered (No additional structural angles or others required).
- If other site conditions vary from those specified on these plans, a job specific engineer will need to be engaged.

* RED LINE INDICATES THE ADDED COLUMN.

- Currently maximum span between columns have been assigned at 6.5m.

3.2 FIRE SHIELDING ON POSTS

CENTRE POST

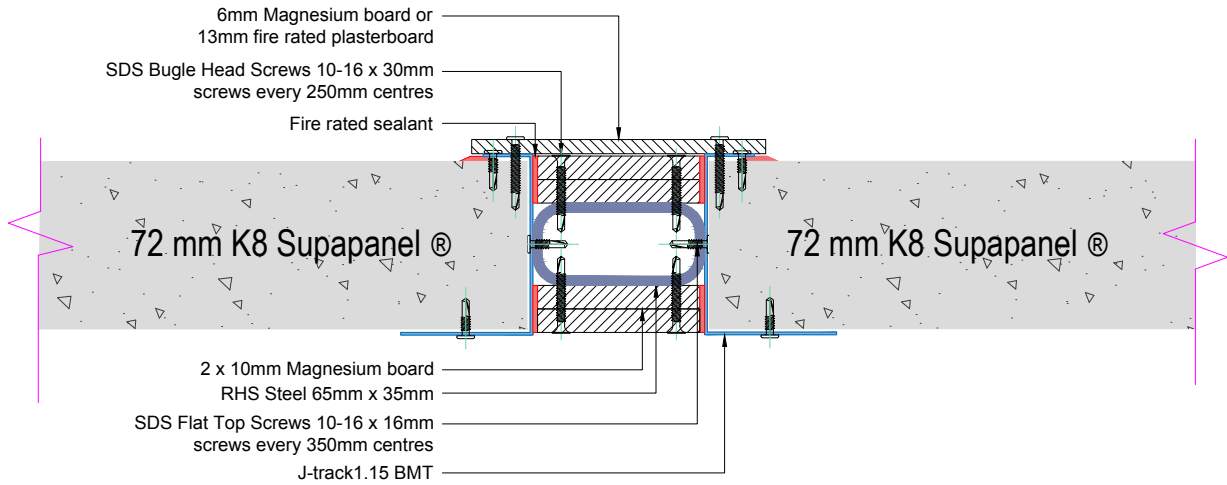

3.3 FIRE SHIELDING ON POSTS

END POST C-TRACK

** 25 MM GAP IN THE TOP TRACK **

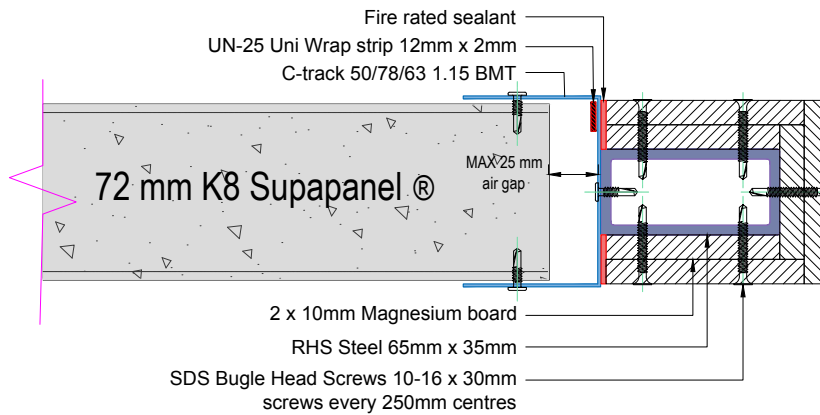

3.4 FIRE SHIELDING ON POSTS

END POST J-TRACK

** J TRACK IS FULLY ENGAGED **

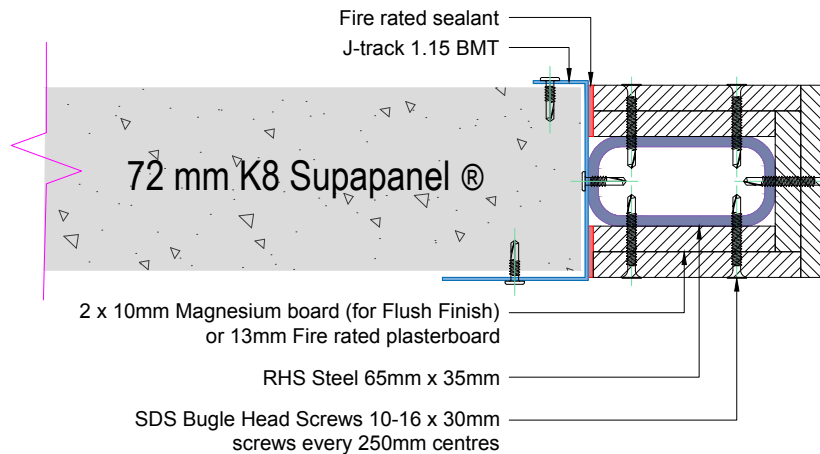

3.5 JUNCTION DETAILS - POST SUSPENDED OFF LANDING

Option 1

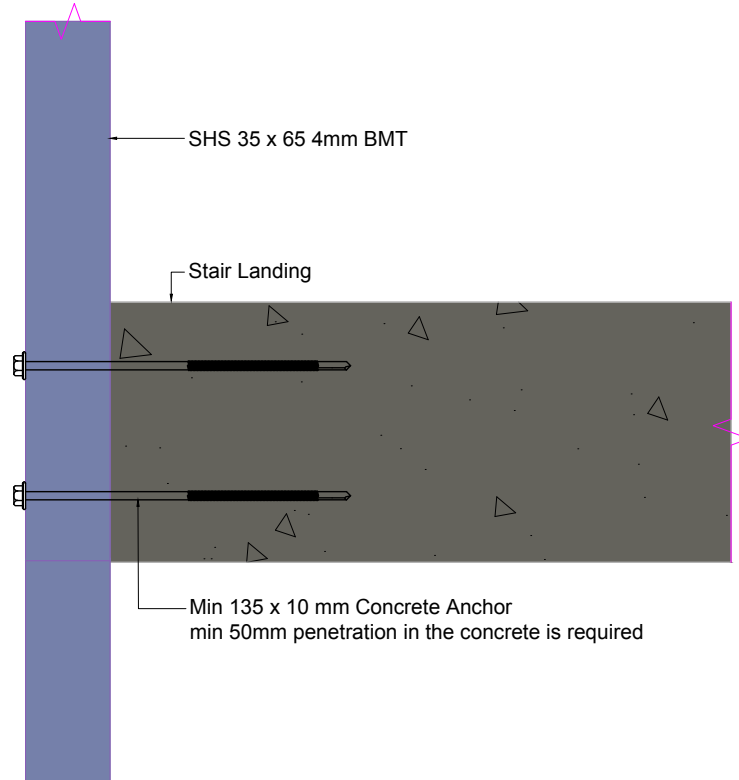

Option 2

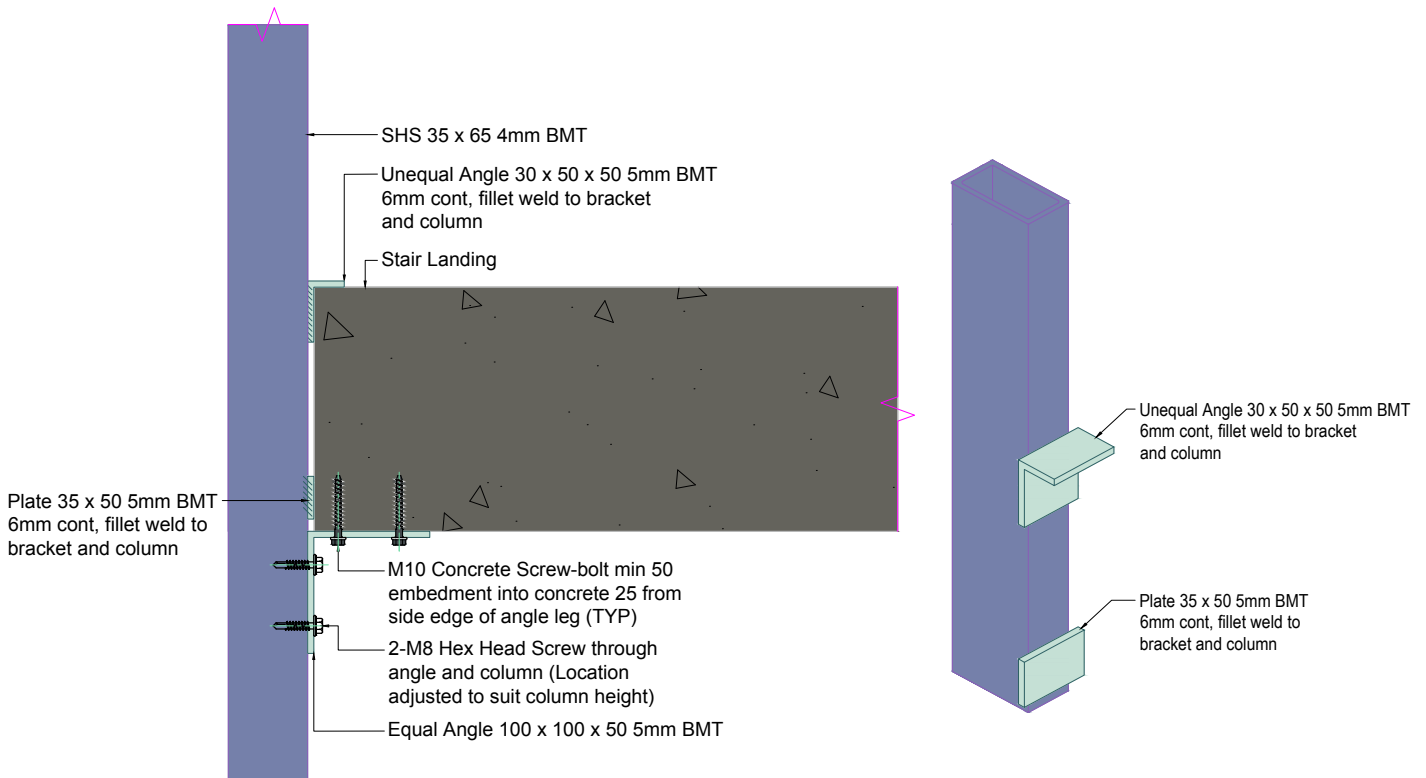

3.6 JUNCTION DETAILS - POST SUSPENDED ON LANDING

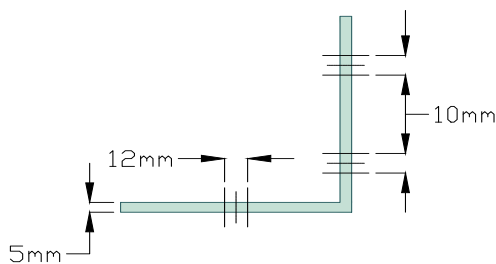
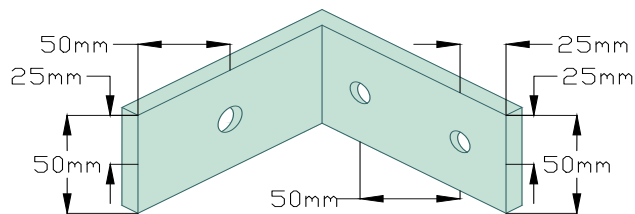
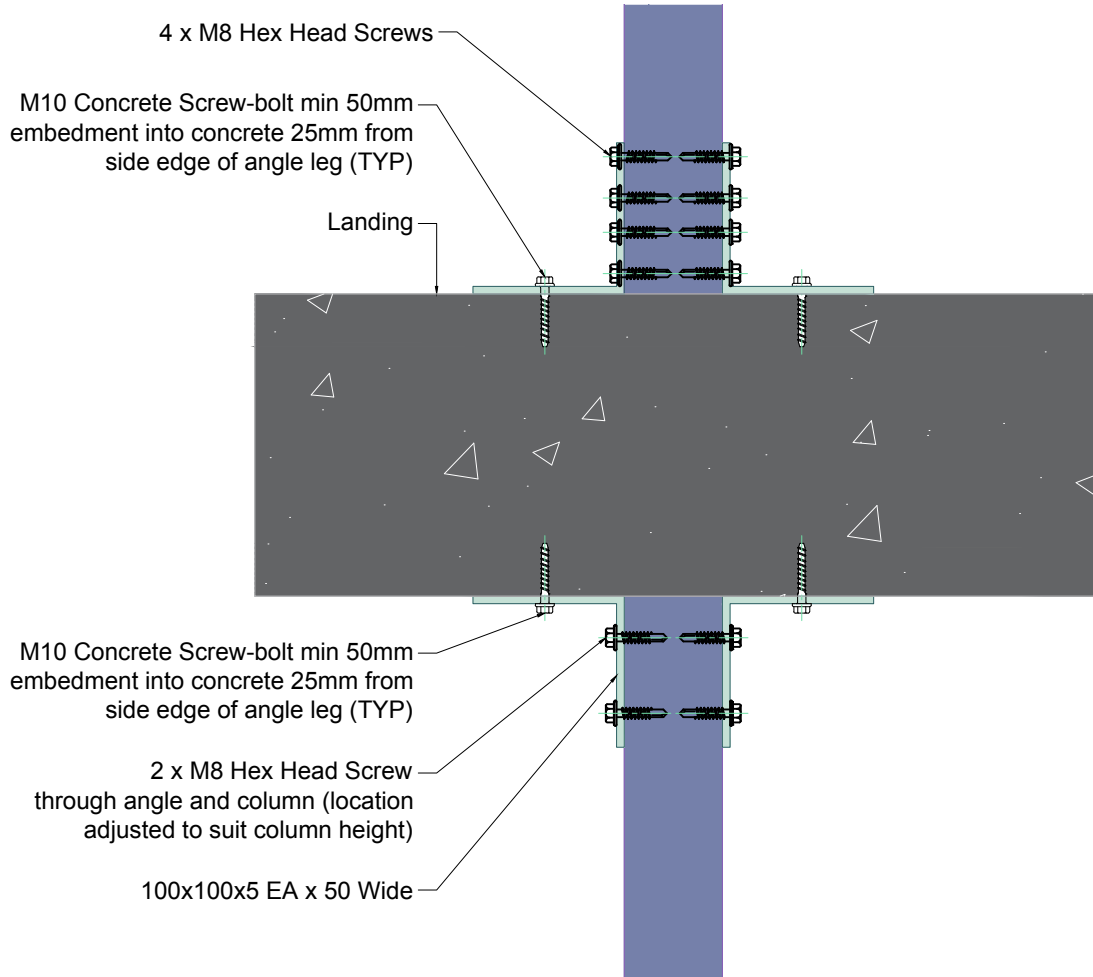

3.7 RECESS POST SUSPENDED OFF LANDINGS

Option 1

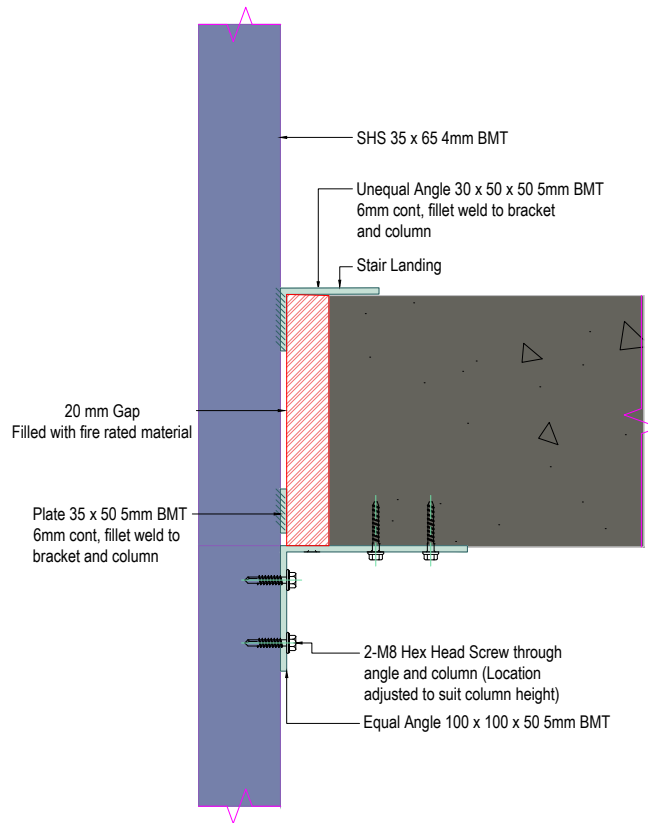

Option 2

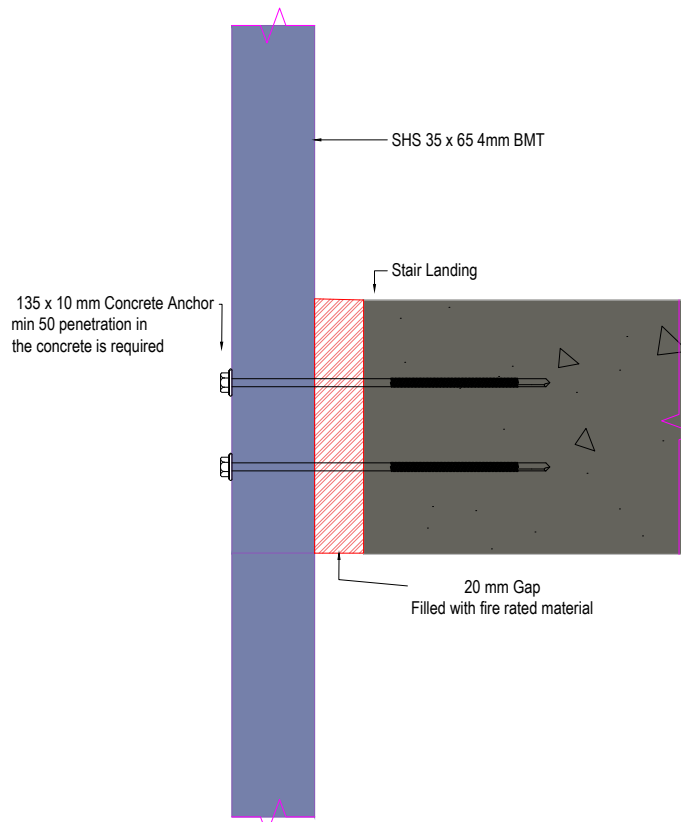

3.8 RECESS POST SUSPENDED ON LANDINGS

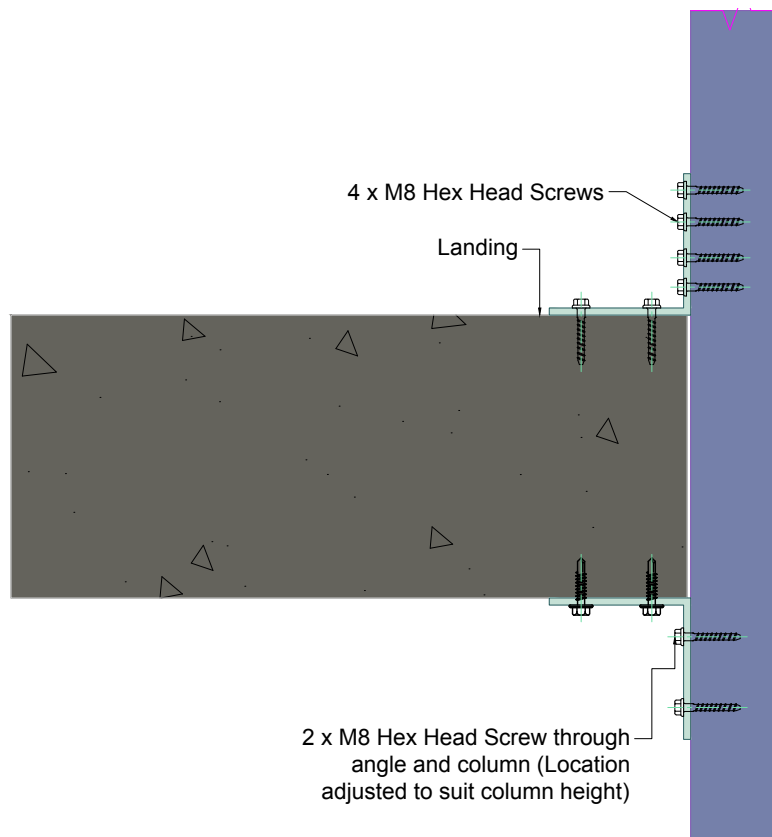

3.9 POST ON CROSS OVER LANDINGS

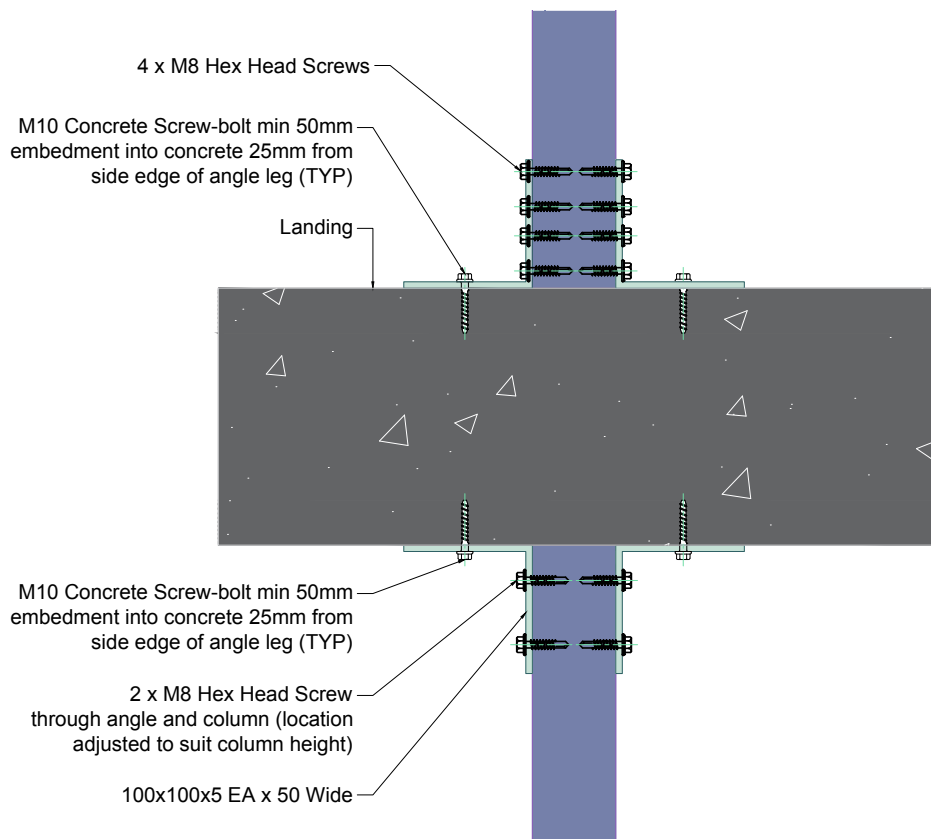

4.0 MID SECTION POSTS RUNNING POST STAIR RISERS

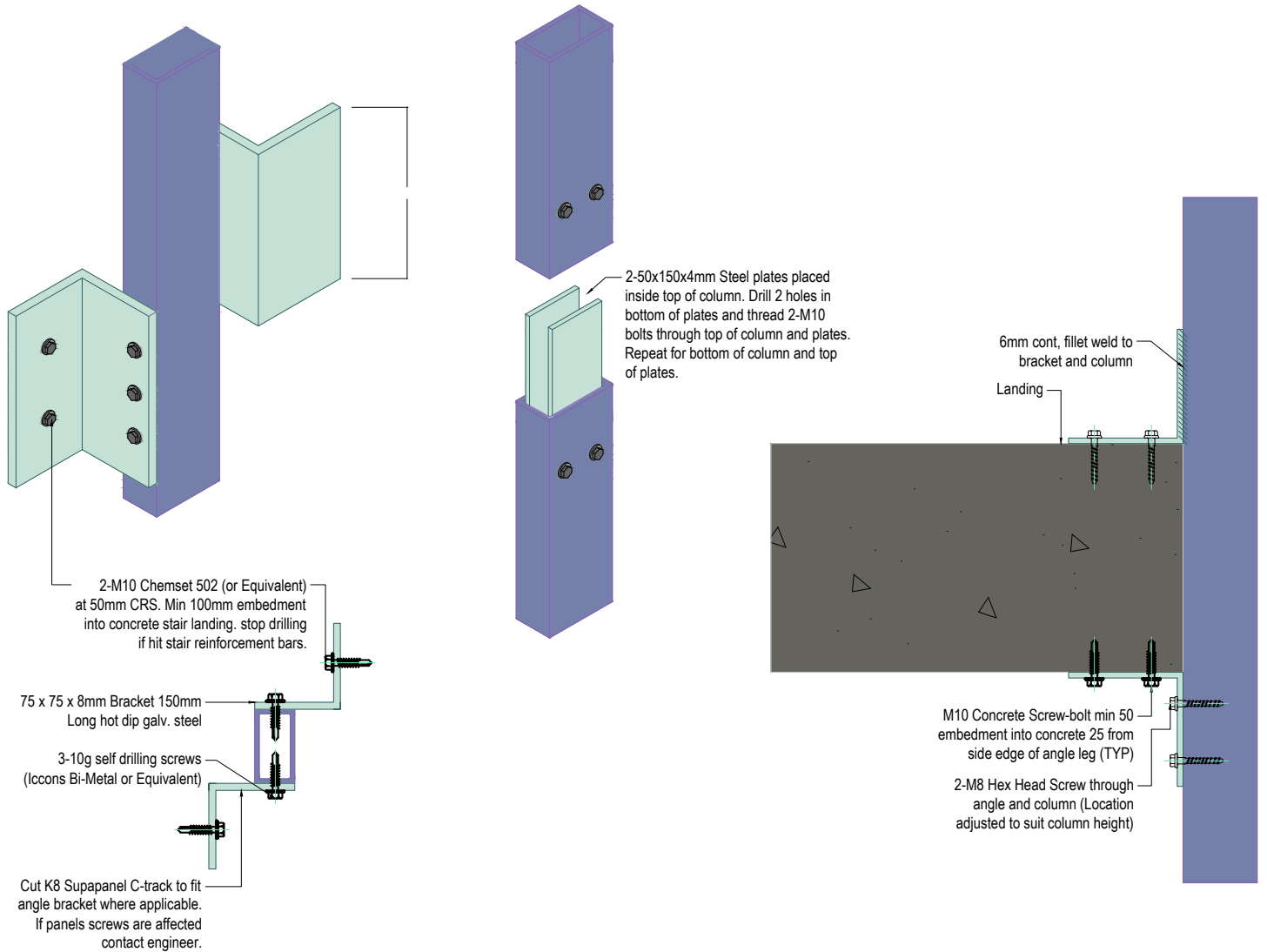

4.1 VARIATION FOR POST HANDRAIL FITTING

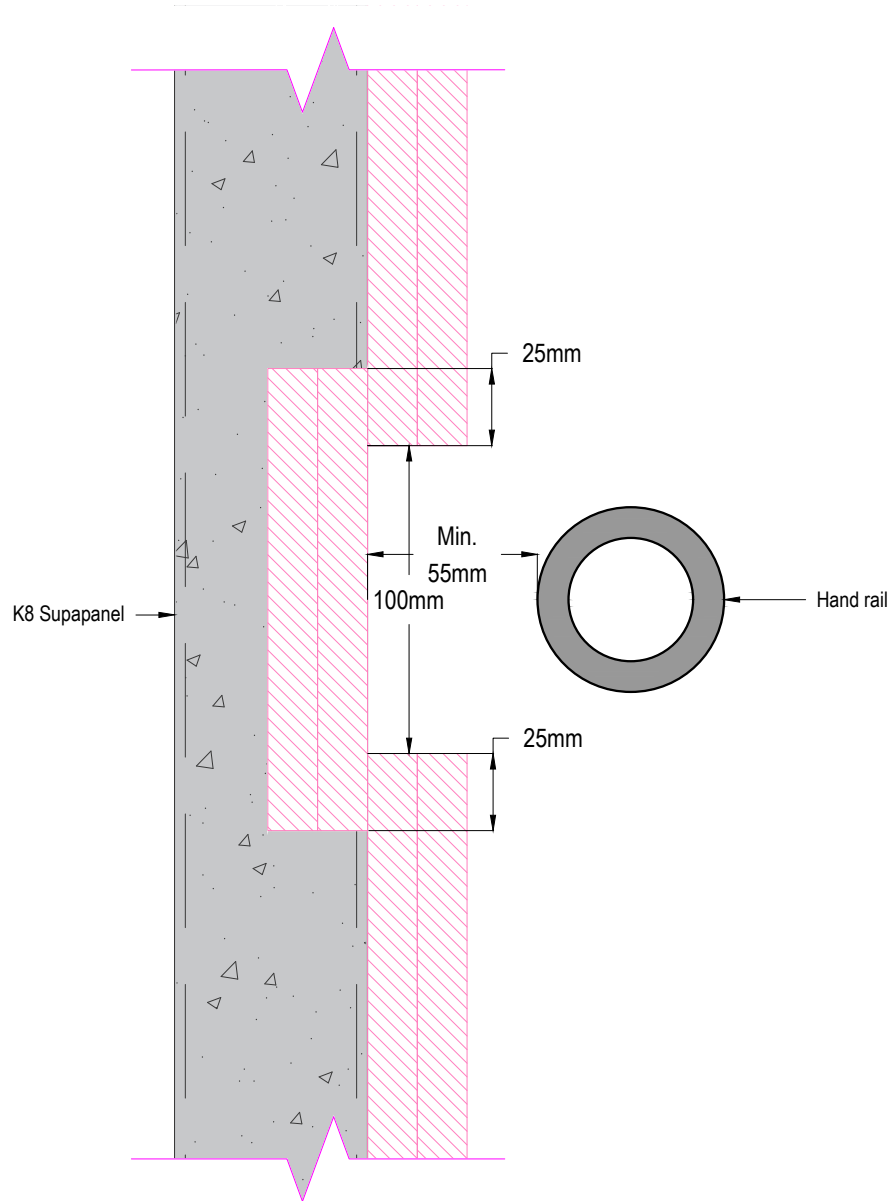

This is to be used when there is insufficient room for fitting the handrail by the landing intersection.

Care, Skill and Attention Required

The performance criteria, ratings, and specifications for various K8 SUPAPANEL® systems have been developed and certified by independent testing bodies. Any products, components or fixings that are not specifically sold by us must be certified for use within the K8 SUPAPANEL® systems by an independent testing body prior to their use within a K8 SUPAPANEL® system or otherwise approved by K8 Australia or any authorised distributor. Use of products or certified by independent testing bodies or approved by K8 Australia may void any warranties on K8 SUPAPANEL® systems. We disclaim all liability for any loss and damage suffered by you from your side of products, components, or fixings within K8 SUPAPANEL® systems that are not K8 SUPAPANEL® products or certified by independent testing bodies or approved by K8 Australia or any authorised distributor. It is critical that you carefully consider the details in your design, construction and workmanship and carry these out with the same due care, skill and diligence. Failure to do so could result in the performance of the K8 SUPAPANEL® systems being significantly compromised and/or may result in failure of K8 SUPAPANEL® systems in your proposed design and/or construction project.

Liability

To the extent permissible by law and without limiting any other right we may have, K8 Australia or any authorised distributor accept no liability for any loss or damage arising if any K8 SUPAPANEL® systems are not designed and constructed strictly in accordance with the instructions contained in this brochure and/or the supplementary material or as otherwise instructed by K8 Australia or an authorised distributor.

Disclaimer

This brochure and the supplementary material are provided to you as a general guide only and should not be relied upon by you without additional advice from a suitably qualified person(s). We do not and will not, under any circumstances, warrant, guarantee or represent, and we disclaim any responsibility or liability for the accuracy, completeness or efficiency of the information contained in this brochure.

Every effort is taken to ensure any updated certification documents and testing data is uploaded onto our website immediately. When enquiring about using K8 SUPAPANEL® for your next project, ensure K8 SUPAPANEL® is compliant for your needs.

All information contained within this brochure and any reports, installation guides, specifications, and/or other supplementary documents and information referred to in this marketing collateral ("Supplementary material") have been prepared by or on behalf of K8 Australia Pty Ltd ("us", "we" or "our") to assist the user of this brochure ("you" or "your") to design and construct K8 SUPAPANEL® systems only in general applications. (None of these included specifications or designs are project or site-specific).

Before designing and/or installing K8 SUPAPANEL® you must engage or seek advice from a suitably qualified person (such as an architect, engineer and/or another design consultant) to, amongst other things:

Review all relevant content in this brochure, the supplementary material and all other product information, installation guides and data available from us upon request;

Assess whether or not K8 SUPAPANEL® systems are appropriate and suitable for your proposed design and/or construction project;

If appropriate & suitable, prepare project specific information and documentation to the design and construction of K8 SUPAPANEL® systems for your proposed project.

Ensure that K8 SUPAPANEL® products separately and collectively, when used in a K8 SUPAPANEL® system, meet the requirements of the building laws, rules, regulations, codes, standards, orders or declarations applicable in the location in which K8 SUPAPANEL® systems are to be constructed.

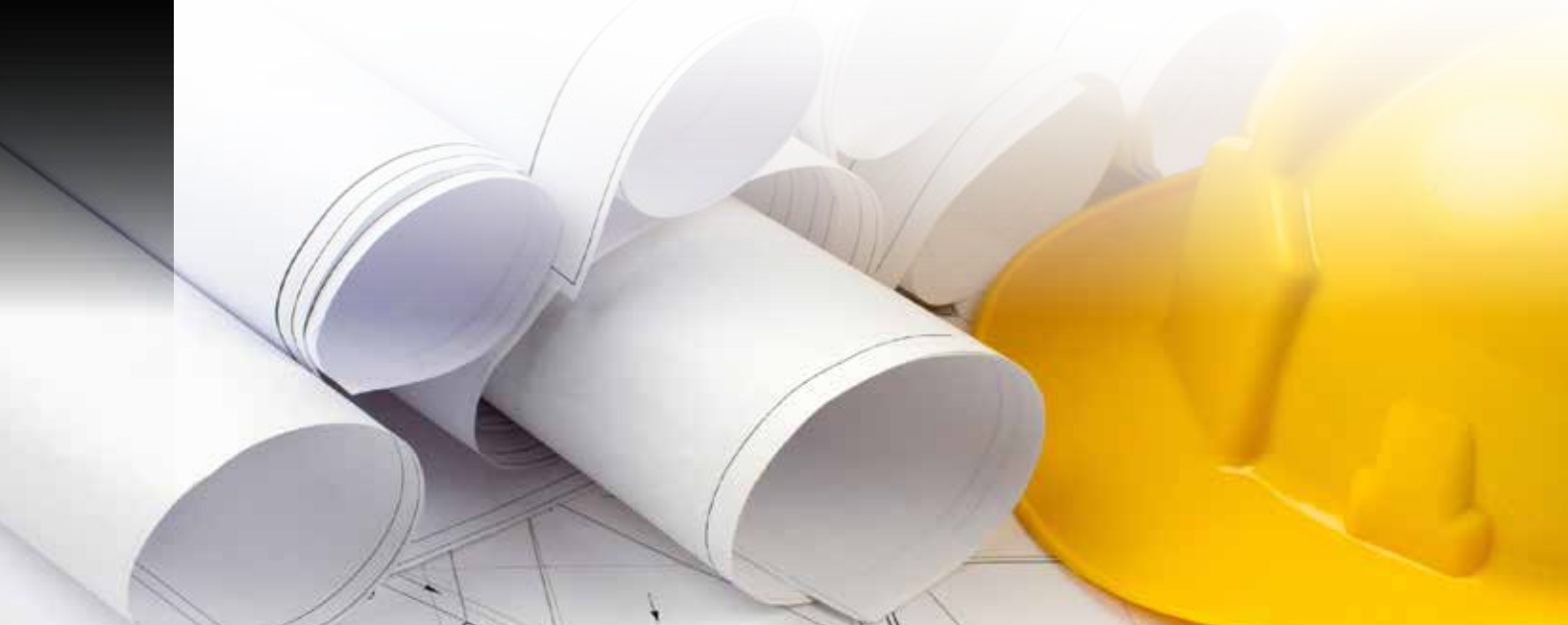



K8  **SUPAPANEL®**

CONTACT

15 LONGFORD COURT,
SPRINGVALE, VIC 3171

David: 0424 207 281
david@k8australia.com.au

www.k8australia.com.au

